



NT91214/15 Series

Tone/Pulse Dialer

Features

- One touch redial operation
- Tone/Pulse switchable
- 32 digit capacity for redialing
- Automatic mixed redialing (last number redial) of pulse to DTMF with multiple automatic access pauses
- PABX auto-pause is 2.2 seconds
- DTMF Timing:
 - Manual dialing: minimum duration for bursts and pauses
 - Redialing: calibrated timing
- Hands-Free control function
- Wide operating voltage range: 2V to 5.5V
- Key-in beep tone output
- Digits dialed manually after redialing are cascable and stored as additional digits for the next redialing
- Uses inexpensive ceramic resonator (3.58 MHz)
- Two versions for different telephone systems
- Built-in power up reset circuit
- Four extra function keys: flash, pause, redial and DP or
 - DTMF mixed dialing
- 4 x 4 (or 2 x 8) keyboard can be used
- Low standby current

General Description

The NT91214/15 is a single-chip, silicon gate, CMOS integrated circuit with an on-chip oscillator for a 3.58MHz crystal or ceramic resonator. It provides a dialing pulse (DP) or dual tone multi-frequency (DTMF) dialing. A standard 4 x 4 matrix keyboard can be used to support either DP or DTMF modes.

Up to 32 digits can be saved in the on-chip RAM for redialing. In the DTMF mode, a short minimum tone duration and minimum intertone pause allows rapid dialing. Maximum tone duration depends on the key depression time during manual dialing.

Pin Configurations

a. 16-Pin Package

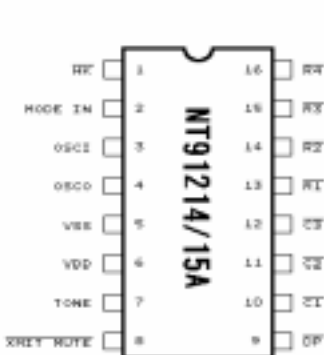

b. 18-Pin Packages (i) Key Tone Output



(ii) Hands-Free Control



c. 20-Pin Package

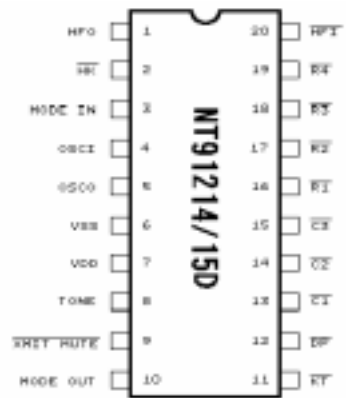

Keyboard Assignments

1	2	3	F1	$\overline{R1}$
4	5	6	F2	$\overline{R2}$
7	8	9	P	$\overline{R3}$
* / T	0	#	RD	$\overline{R4}$

$\overline{C1}$ $\overline{C2}$ $\overline{C3}$ GND

1. * / T -- In PULSE mode this key works as Pulse → DTMF key (T key). In DTMF mode the key works as * key. * / T key will occupy one memory digit in either use.
2. F1 -- Flash key. The break time is 297 ms or 96 ms (NT91214/15 respectively)
3. F2 -- Flash key for break time 640 ms
4. P -- Pause key (2.2 seconds)
5. RD -- One key redial key
6. # -- In PULSE mode this key input is neglected. In DTMF mode this key works as # key.

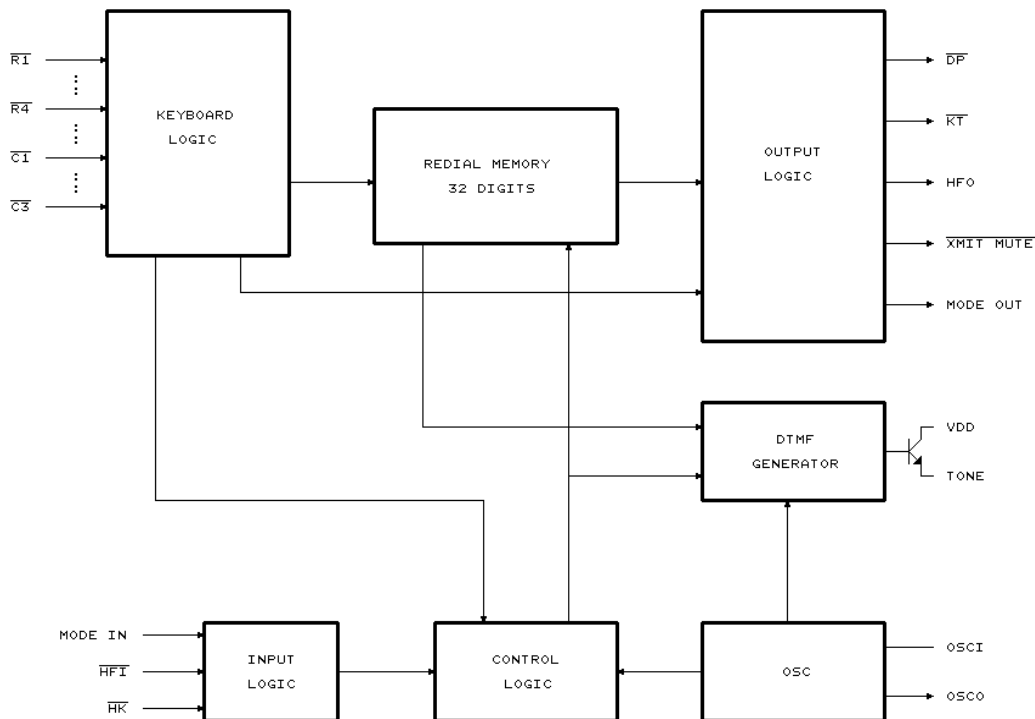
Block Diagram

Absolute Maximum Ratings*

Supply Voltage (VDD) ≤ 6.0V
 Input Voltage (VIN) VSS - 0.3V to VDD + 0.3V
 Output Voltage (VOUT) VSS - 0.3V to VDD + 0.3V
 Output Voltage (VOUT)(\overline{DP} , \overline{XMIT} \overline{MUTE}) ≤ 1.2V
 Tone Output Current (ITONE) ≤ 50mA
 Power Dissipation (PD) ≤ 500mW
 Operating Temperature (Top) -20°C to +70°C
 Storage Temperature (Tstg) -40°C to +150°C

***Comments**

Stresses above those listed under "Absolute Maximum Ratings" may cause permanent damage to this device. These are stress ratings only. Functional operation of this device at these or any other conditions above those indicated in the operational sections of this specification is not implied or intended. Exposure to the absolute maximum rating conditions for extended periods may affect device reliability.

DC Electrical Characteristics (VDD = 3.5V, VSS = 0V, Fosc = 3.579MHz, Top = 25°C)

Parameter	Symbol	Min.	Typ.	Max.	Unit	Conditions	Test KT.	
Operating Voltage	VDD	2.0		5.5	V	PULSE mode	A	
		2.0		5.5		TONE mode		
Memory Retention Voltage	VMR	1			V		-	
Memory Retention Current	IMR		0.05	0.4	μA	VDD = 1.0V, \overline{HK} = VDD All outputs unloaded	-	
Operating Current	IDDP		0.32	1.0	mA	Pulse mode	All outputs unloaded	A
	IDDT		0.6	2.0		Tone mode		
Standby Current	Iso		0.03	0.05	μA	\overline{HK} = VDD = 1.5V	All outputs unloaded, no key selected	A
			0.5	10		\overline{HK} = VSS		
Input Current	VIH	0.8		1	VDD			
	VIL	0		0.2				
$\overline{R1}$ - $\overline{R4}$ Input Current	IR		115		μA		C	
Tone out Voltage	Voc	584	730	876	mVp-p	Column	VDD = 3.5V RL = 5K	D
	VoR	456	570	684		Row		
\overline{HFI} Pull Low Current	IHFI		5		μA	VDD = 3.5V (Note 1) \overline{HFI} pin connected to 0V	B	

DC Electrical Characteristics (continued)

Parameter	Symbol	Min.	Typ.	Max.	Unit	Conditions	Test KT.
HFO Drive Current	$ I_{OH1} $	0.4	2		mA	VDD = 3.5V VoH = VDD - 0.4V	B
HFO, \overline{KT} , MODEOUT $\overline{XMITMUTE}$ Sink Current	I_{OL1}	0.9	5.3		mA	VDD = 3.5V VoL = 0.4V	B
\overline{DP} Sink Current	I_{OL2}	1.1	5.3		mA	VDD = 3.5V, VoL = 0.4V	B
Distortion	DIS%		1	5	%	* see note below	

* Note:
$$DIS\% = \frac{100 * (V_1^2 + V_2^2 + \dots + V_n^2)^{1/2}}{(V_{IL}^2 + V_{IH}^2)^{1/2}}$$

1. V_1, \dots, V_n are the intermodulation or the harmonic frequencies in the 500Hz to 3400Hz band.
2. V_{IL} and V_{IH} are the individual frequency components of the DTMF signal.

AC Characteristics (VDD = 3.5V, VSS = 0V, Fosc = 3.579MHz, Top = 25°C, unless otherwise specified.)

Parameter	Symbol	Min.	Typ.	Max.	Unit	Conditions
Make Time	T_M		33.3		ms	10pps M/B = 1/2
			40.0			M/B = 2/3
			16.7			20pps M/B = 1/2
			20.0			M/B = 2/3
Break Time	T_B		66.6		ms	10pps M/B = 1/2
			60.0			M/B = 2/3
			33.3			20pps M/B = 1/2
			30.0			M/B = 2/3
Inter-digit Pause Time	T_{IDP}		824		ms	10pps
			458			20pps
Pause Time	T_{PAU}		2.2		sec	

AC Characteristics (continued)

Parameter	Symbol	Min.	Typ.	Max.	Unit	Conditions
Auto-redial Break Time	T _{AOBK}		2.2		sec	* Optional
Delay time Key valid to Signal Out	T _D		0		ms	
Key-in Debounce	T _{KD}		21		ms	
Key Release Debounce Time	T _{KLD}		5.2		ms	
Key-in Tone Duration	T _{KTD}		23		ms	
Key-in Tone Frequency	F _{KT}		437		Hz	
Minimum Tone Duration Time	T _{MFD}		94		ms	
Min. Tone Inter-digit Pause	T _{TIDP}		96		ms	
Redial Tone Duration	T _{MFDR}		94		ms	
Redial Tone Inter-digit Duration	T _{TIDPR}		96		ms	

Comparisons of Specified vs. Actual Tone Frequencies

R/C	Spec.	Actual	Error (%)	Unit	Conditions
$\overline{R1}$	697	699.1	+0.31	Hz	Fosc = 3.579MHz
$\overline{R2}$	770	771.5	+0.19	Hz	
$\overline{R3}$	852	852.3	+0.03	Hz	
$\overline{R4}$	941	942.0	+0.10	Hz	
$\overline{C1}$	1,209	1,215.7	+0.57	Hz	
$\overline{C2}$	1,336	1,331.7	-0.32	Hz	
$\overline{C3}$	1,477	1,471.9	-0.35	Hz	

Pin Descriptions

Pin No.				Designation	I/O	Description																																
NT91215A NT91214A	NT91215B NT91214B	NT91215C NT91214C	NT91215D NT91214D																																			
3 4	3 4	4 5	4 5	OSCI OSCO	I	Oscillator Input and Output pins The time base for the NT91214/15 is a crystal controlled on-chip oscillator, which is completed by connecting a 3.58MHz crystal or ceramic resonator between the OSCI and OSKO pins.																																
2	2	3	3	MODE IN	I, Z	TRI-STATE mode select pin There are two versions of the NT91214/15 as follows: a. NT91215 Series is for European and American systems. <table border="1" data-bbox="1027 840 1442 1050"> <thead> <tr> <th>MODE IN</th> <th>Tone/Pulse</th> <th>Dial Rate</th> <th>M/B Ratio</th> </tr> </thead> <tbody> <tr> <td>VDD</td> <td>Pulse</td> <td>10pps</td> <td>2/3</td> </tr> <tr> <td>VSS</td> <td>Tone</td> <td>-</td> <td>-</td> </tr> <tr> <td>Floating</td> <td>Pulse</td> <td>10pps</td> <td>1/2</td> </tr> </tbody> </table> b. The NT91214 Series is for the Japanese system. <table border="1" data-bbox="1027 1134 1442 1344"> <thead> <tr> <th>MODE IN</th> <th>Tone/Pulse</th> <th>Dial Rate</th> <th>M/B Ratio</th> </tr> </thead> <tbody> <tr> <td>VDD</td> <td>Pulse</td> <td>10pps</td> <td>1/2</td> </tr> <tr> <td>VSS</td> <td>Tone</td> <td>-</td> <td>-</td> </tr> <tr> <td>Floating</td> <td>Pulse</td> <td>20pps</td> <td>1/2</td> </tr> </tbody> </table> The mode selection pin is checked for tone/pulse dialing as each digit key entry. In the PULSE mode, the dialing rate is checked, along with the make/break ratio, at first key entry.	MODE IN	Tone/Pulse	Dial Rate	M/B Ratio	VDD	Pulse	10pps	2/3	VSS	Tone	-	-	Floating	Pulse	10pps	1/2	MODE IN	Tone/Pulse	Dial Rate	M/B Ratio	VDD	Pulse	10pps	1/2	VSS	Tone	-	-	Floating	Pulse	20pps	1/2
MODE IN	Tone/Pulse	Dial Rate	M/B Ratio																																			
VDD	Pulse	10pps	2/3																																			
VSS	Tone	-	-																																			
Floating	Pulse	10pps	1/2																																			
MODE IN	Tone/Pulse	Dial Rate	M/B Ratio																																			
VDD	Pulse	10pps	1/2																																			
VSS	Tone	-	-																																			
Floating	Pulse	20pps	1/2																																			

Pin Descriptions (continued)

Pin No.				Designation	I/O	Description
NT91215A NT91214A	NT91215B NT91214B	NT91215C NT91214C	NT91215D NT91214D			
1	1	2	2	\overline{HK}	I	Hook switch input This inverter input pin detects the state of the hook switch contact. "Off Hook" is represented by a VSS condition. "On Hook" is represented by a VDD condition.
(N.A.)	10	(N.A.)	11	\overline{KT}	O	Key-in tone output This N-channel open drain pin sends out a "beep" tone for each PULSE mode key entry, along with entries of accepted function keys (RD, T, F1 F2, and P keys). The tone output frequency is 437Hz and tone duration is 23 ms.
9	11	10	12	\overline{DP}	O	Dialing pulse output This is an N-channel open drain output. The normal output will be "ON" during break and "OFF" during make in the PULSE DIALING mode.

Pin Descriptions (continued)

Pin No.				Designation	I/O	Description																																								
NT91215A NT91214A	NT91215B NT91214B	NT91215C NT91214C	NT91215D NT91214D																																											
(N.A.)	(N.A.)	1	1	HFO	O	Hands-Free Control I/O pins These pins enable and disable the Hands-Free control function. When input pin $\overline{\text{HFI}}$ goes low, the Hands-Free Control state is toggled on. The status of the Hands-Free control state is listed in the following table: <table border="1" data-bbox="1019 680 1463 1314"> <thead> <tr> <th colspan="2">Current State</th> <th colspan="3">Next State</th> </tr> <tr> <th>Hook sw.</th> <th>HFO</th> <th>Input</th> <th>HFO</th> <th>Dialing?</th> </tr> </thead> <tbody> <tr> <td>-</td> <td>Low</td> <td>$\overline{\text{HFI}}$ ↓</td> <td>High</td> <td>Yes</td> </tr> <tr> <td>On Hook</td> <td>High</td> <td>$\overline{\text{HFI}}$ ↓</td> <td>Low</td> <td>No</td> </tr> <tr> <td>Off Hook</td> <td>High</td> <td>$\overline{\text{HFI}}$ ↓</td> <td>Low</td> <td>Yes</td> </tr> <tr> <td>On Hook</td> <td>-</td> <td>Off Hook</td> <td>Low</td> <td>Yes</td> </tr> <tr> <td>Off Hook</td> <td>Low</td> <td>On Hook</td> <td>Low</td> <td>No</td> </tr> <tr> <td>Off Hook</td> <td>High</td> <td>On Hook</td> <td>High</td> <td>Yes</td> </tr> </tbody> </table>	Current State		Next State			Hook sw.	HFO	Input	HFO	Dialing?	-	Low	$\overline{\text{HFI}}$ ↓	High	Yes	On Hook	High	$\overline{\text{HFI}}$ ↓	Low	No	Off Hook	High	$\overline{\text{HFI}}$ ↓	Low	Yes	On Hook	-	Off Hook	Low	Yes	Off Hook	Low	On Hook	Low	No	Off Hook	High	On Hook	High	Yes
		Current State		Next State																																										
Hook sw.	HFO	Input	HFO	Dialing?																																										
-	Low	$\overline{\text{HFI}}$ ↓	High	Yes																																										
On Hook	High	$\overline{\text{HFI}}$ ↓	Low	No																																										
Off Hook	High	$\overline{\text{HFI}}$ ↓	Low	Yes																																										
On Hook	-	Off Hook	Low	Yes																																										
Off Hook	Low	On Hook	Low	No																																										
Off Hook	High	On Hook	High	Yes																																										
		18	20	$\overline{\text{HFI}}$	I																																									
7	7	8	8	TONE	O	Tone dialing output When a valid keypress is detected in the DTMF mode, appropriate low group and high group, frequencies are generated which hybridizes the dual tone output. TONE output is in the "OFF" state in PULSE mode.																																								

Pin Descriptions (continued)

Pin No.				Designation	I/O	Description
NT91215A NT91214A	NT91215B NT91214B	NT91215C NT91214C	NT91215D NT91214D			
8	8	9	9	$\overline{\text{XMITMUTE}}$	O	Dialing transmission mute output This is an N-channel open drain output The $\overline{\text{XMITMUTE}}$ is normally "OFF" During pulse of DTMF dialing this output is "ON".
(N.A.)	9	(N.A.)	10	MODE OUT	O	Mode output pin This is an N-channel, open drain output It is "ON" during tone output and "OFF" during pulse output.
13	15	14	16	$\overline{\text{R1}}$		Keyboard pins This input serves as the interface to an XY matrix keyboard. On a 4 x 4 matrix keyboard, the input from the fourth column, $\overline{\text{C4}}$, should be connected to VSS.
14	16	15	17	$\overline{\text{R2}}$		
15	17	16	18	$\overline{\text{R3}}$		
16	18	17	19	$\overline{\text{R4}}$		
10	12	11	13	$\overline{\text{C1}}$		
11	13	12	14	$\overline{\text{C2}}$		
12	14	13	15	$\overline{\text{C3}}$		
6	6	7	7	VDD		Power supply pins These devices are designed to operate from 2.0V to 5.5V.
5	5	6	6	VSS		

Operating Procedures

Symbol Definitions:

In the description below, signals are defined in terms of the key or switch which is activated.

Off Hook means the phone is off the hook.

On Hook means that the phone is on the hook.

D1 represents for the first digit dialed in a string of digits.

Dn (**Dk**) represents for the last digit dialed in a string of digits.

Dn+1 represents for the beginning of a new string of digits.

Dn+m represents for the last digit in a new string of digits.

HFI↓ represents for the switch that activates the HANDS-FREE DIALING mode going low

***/T** is the Pulse-to-DTMF key

RD is the Redial key.

0 is the Zero key.

P is the Pause key.

F is the Flash key.

Recommended Operation:

1. PULSE mode operation

a. **Off Hook** **D1** ... **Dn**

PULSE mode is defined as the INITIAL mode, provided

the first keyboard input is not the ***/T** key following the **Off Hook** condition and the mode selection pin is

floating (MODE IN = VDD or floating).

b. **On Hook** **HFI↓** **D1** ... **Dn**

Pulse mode is defined as the INITIAL mode, provided the key input **D1** is not ***/T** while the mode selection pin is VDD or floating. The chip will pause for 824 ms automatically after it detects an **Off Hook** condition or if the **HFI↓** key is depressed. It then proceeds with pulse or DTMF dialing if any keys have been depressed.

The dialing rate or make/break ratio is decided at the first key entry by checking the MODE IN status and will

not be altered. The MODE IN status can only switch the DIALING mode from PULSE to DTMF after the first

key entry.

2. DTMF mode operation

a. **Off Hook** **D1** ... **Dn** or **On Hook** **HFI↓** **D1** ... **Dn**

DTMF mode is defined as the INITIAL mode if the mode selection pin MODE IN is VSS.

b. **Off Hook** ***/T** **D1** ... **Dn** or **On Hook** **HFI↓** ***/T** **D1** ... **Dn**

The INITIAL mode is PULSE mode if the mode selection pin, MODE IN, is VDD or floating. The ***/T** key can switch the DIALING mode to TONE mode.

Unlike NORMAL mode switching, the ***/T** key entry,

as the first key pressed, will not produce any pause time. There are only 31 digits of redial memory available in the buffer to be used for operations a and b, since the mode switching key, */T, will occupy one digit of space.

3. Manual dialing with automatic access pause

a. Off Hook O P D1 ... Dn

pause key entries can be accepted and stored in the redial memory. Each is stored as a digit.

Each key-in will provide a pause of 3.57 seconds, depending on which model is being used.

4. Redial

a. On Hook RD or On Hook HF1↓ RD

Up to 32 digits (in PULSE mode) or 31 digits (in TONE mode) can be dialed using the RD key.

The RD key is disabled while PULSE or TONE signals are being transmitted. Redial will also be inhibited if the last number dialed exceeds 32 digits because the redial memory can only hold 32 digits.

b. Off Hook RD D1 .. Dn or On Hook
HF1↓ RD D1 .. Dn

After pressing the RD key, digits may be added to the number in redial memory. When finished dialing, the redial memory will contain the original digits, plus the digits dialed after pressing RD. Each time the redial key is pressed, the stored number will be dialed exactly the same as it was previously, regardless of the status of the MODE IN pin.

5. TONE/PULSE switching operation

a. On Hook D1 ... Dn MODE IN pin

← PULSE Mode

switched to VSS Dn+1 ... Dn+m

→ DTMF Mode →

The mode selection pin is always checked for TONE or PULSE mode key entry. Dialing can be switched from PULSE to TONE mode, but not from TONE to PULSE mode. Switching the MODE IN pin to the original digits plus the digits dialed after pressing will cause the chip to store a */T digit prior to the first tone digit in the redial memory and will automatically insert a 2.2 second pause before the tone digits are dialed out. After the mode has been switched, the status of the mode selection pin will no longer be checked. Therefore, it will not be possible to switch from TONE to PULSE mode.

b. Off Hook D1 ... Dn */T Dn+1

← PULSE Mode →

. . . Dn+m

DTMF Mode →

PULSE mode is initially defined with the mode selection pin, MODE IN, equal to VDD or floating. At this time, the mode can be switched to DTMF by pressing the */T key. DTMF mode will begin as soon as the last pulse has been transmitted. In this mode, Dn+1 through Dn+m are sent through the TONE OUT pin as DTMF signals. If a P key entry is contained in the series of digits before or after the */T entry, or the MODE IN switch is depressed, 2.2 second pause will be added to the automatically inserted pausetime, which is also 3.57 seconds. Both of the

above switching modes can store as many as 31 digits

in the redial memory.

6. One-key redialing

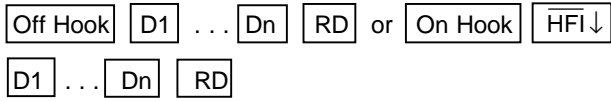

If the dialing of [D1] to [Dn] is finished, pressing [RD] will cause the pulse dialing pin to go low for 1.67 seconds of break time and an 824 ms pause will automatically be added. If the pulses of the number dialed with [D1] to [Dn] have not finished, the pressing of the redial key will be ignored.

7. Flash dialing

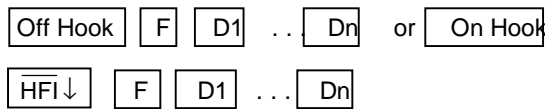

The flash keys emulate quick On-Off Hook operations. Pressing the flash keys, [F1] or [F2], will cause a

break of 96 ms or 640 ms (or, 297 ms or 640 ms, depending on the model) on the \overline{DP} output pin. Then, it pauses for 824 ms and continues dialing the digits, [D1] to [Dn]. These digits are then stored in the redial memory.

Each time the flash key is pressed, the redial memory will

be cleared to store a new entry. In addition, the MODE IN

status will be checked again for the setting of the TONE/PULSE DIALING mode.

Similarly, to make sure that the IC is working properly, new flash key inputs will be ignored as long as the digits that were dialed have not finished.

Timing Waveforms

1. Timing Waveform in PULSE Mode:

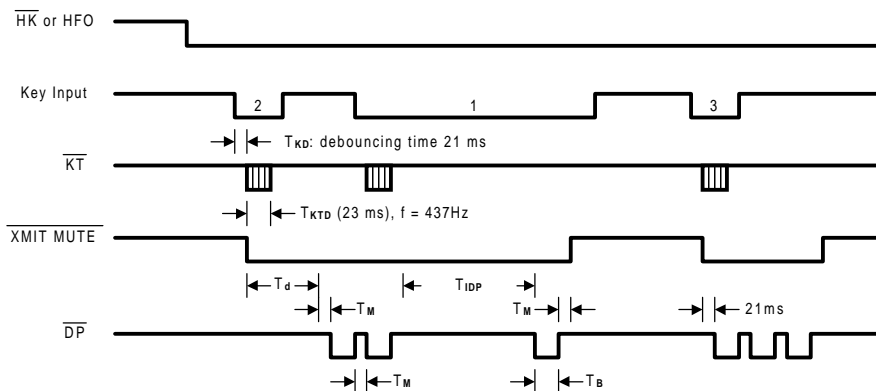

- Td: Delay time of Key valid to dialing signal out, typically 0ms
- TIDP: Inter-digit pause time
- TKT0: Key-in tone duration
- TKD: Debouncing time

Note: "HK" or "HFO" indicates chip works when hook switch "HK" goes low or Hands-Free control output HFO goes high.

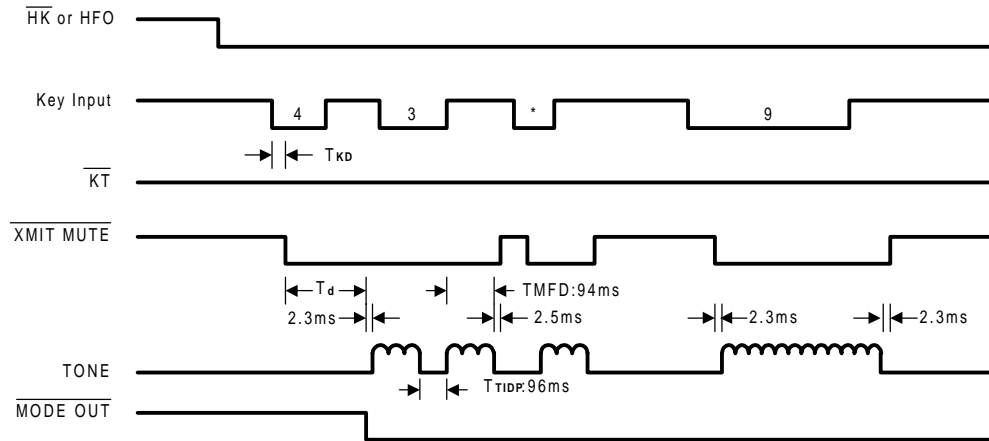
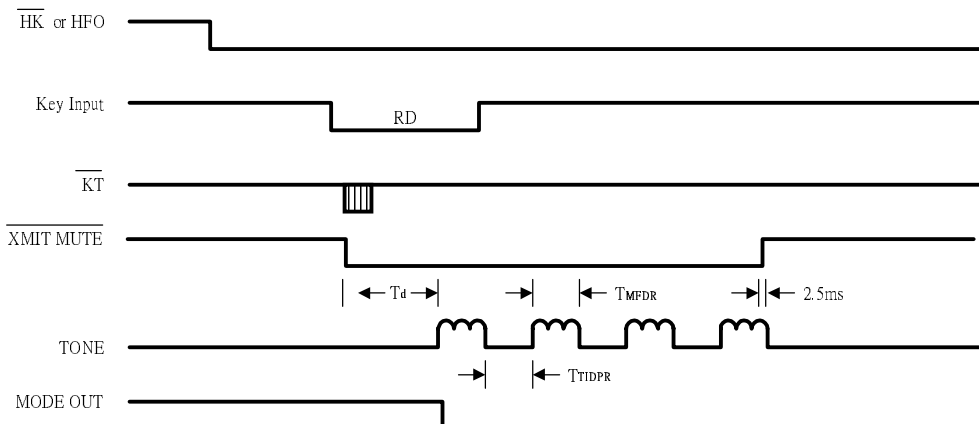
Timing Waveforms (continued)
2. Timing Waveform in TONE Mode:
(i) Normal Dialing

(ii) After (i), Redialing

Timing Waveforms (continued)
3. Timing waveform for SWITCHING Mode Operation:

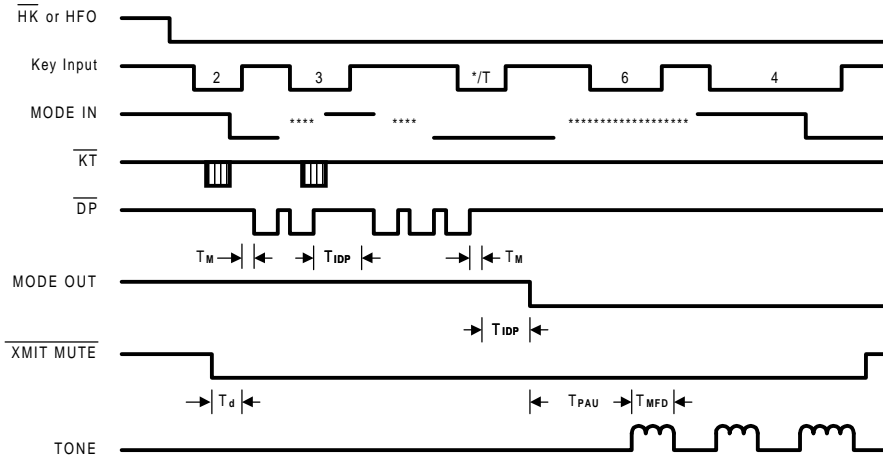
(i) By mode selection pin switches

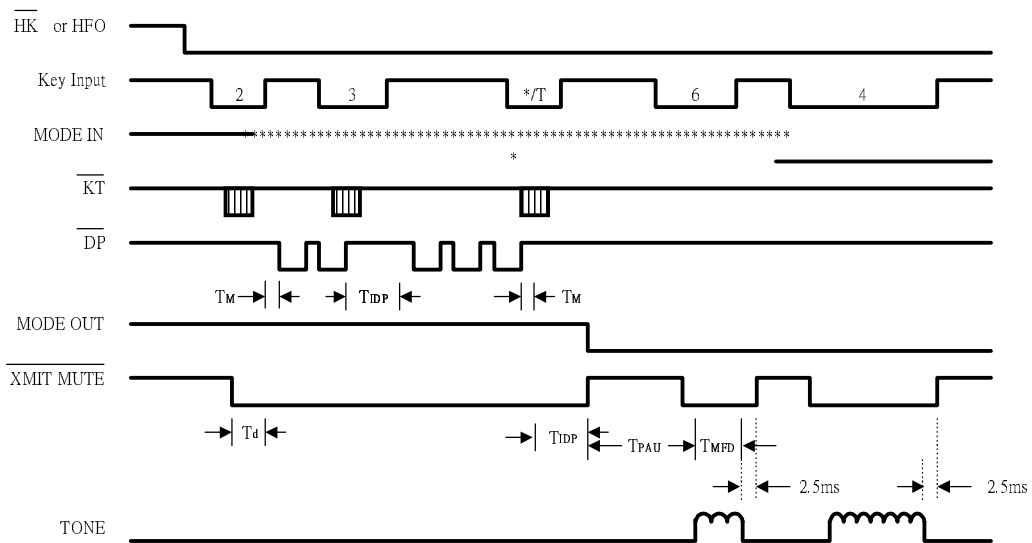

(ii) By */T key entry

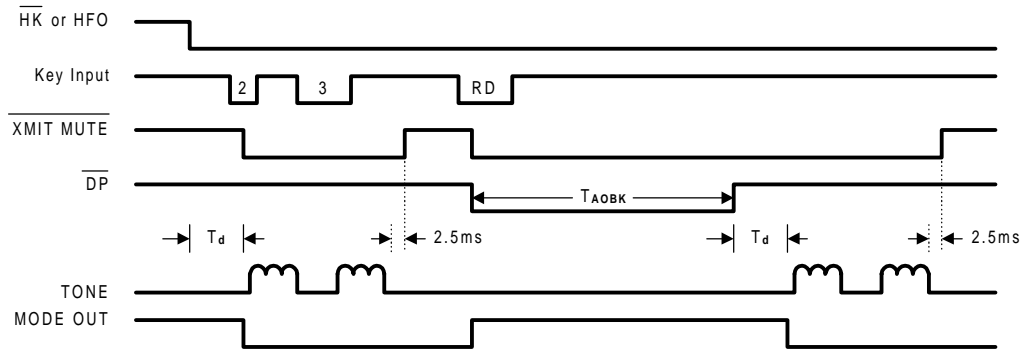

 T_{PAU} : Pause time (2.2 secs)

Timing Waveforms(continued)
4. One Key Redial (DTMF mode used as example):

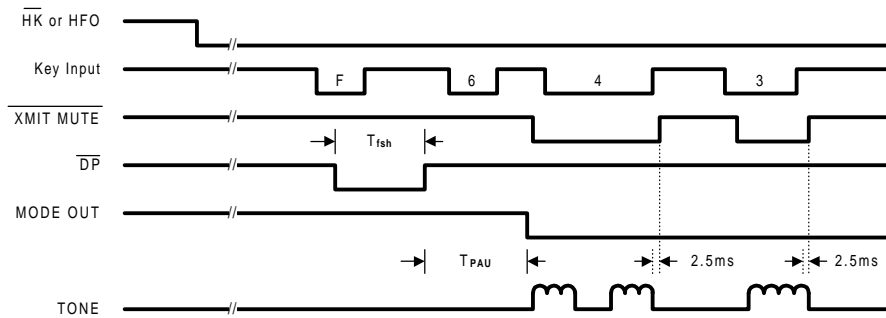
$T_{\Delta 0BK}$: Break time (2.2 secs)

5. Flash Dialing (DTMF mode used as example):

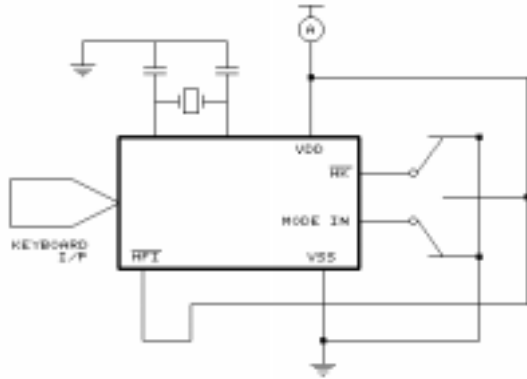
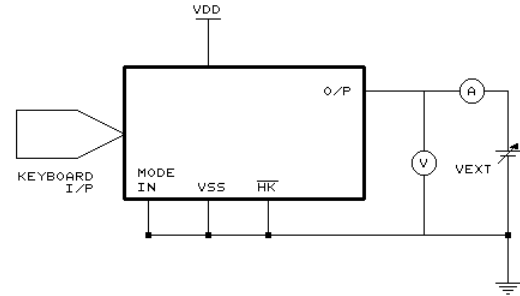
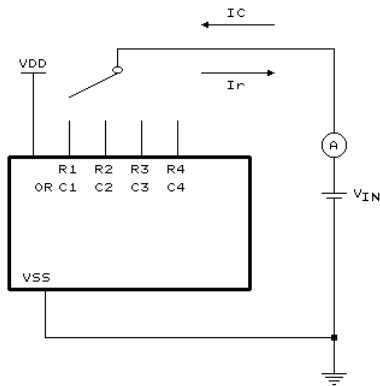
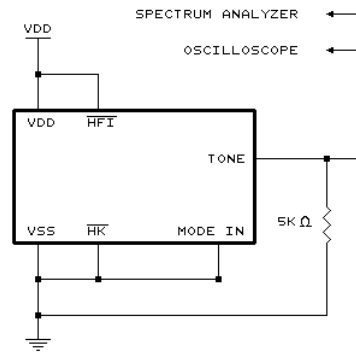
T_{fsh} : flash time 96 or 640 ms (F1 or F2 respectively) for NT91215
 flash time 297 or 640 ms (F1 or F2 respectively) for NT91214

Test Circuits
(A)

(B)

(C)

(D)

OSCILLOSCOPE: TEKTRONIX 468
SPECTRUM ANALYZER: HP3585A

Ordering Information

Part No.	Key Tone	Hands-Free Control	Dial Rate	M/B Ratio	Flash		Package
					F1	F2	
NT91214A	N.A.	N.A.	10/20pps	1/2	297 ms	640 ms	16L DIP
NT91214B	A	N.A.					18L DIP
NT91214C	N.A.	A					18L DIP
NT91214D	A	A					20L DIP
NT91215A	N.A.	N.A.	10pps	1/2 2/3 selectable	96 ms	640 ms	16L DIP
NT91215B	A	N.A.					18L DIP
NT91215C	N.A.	A					18L DIP
NT91215D	A	A					20L DIP

Package Information
DIP 16L Outline Dimensions

unit: inches/mm

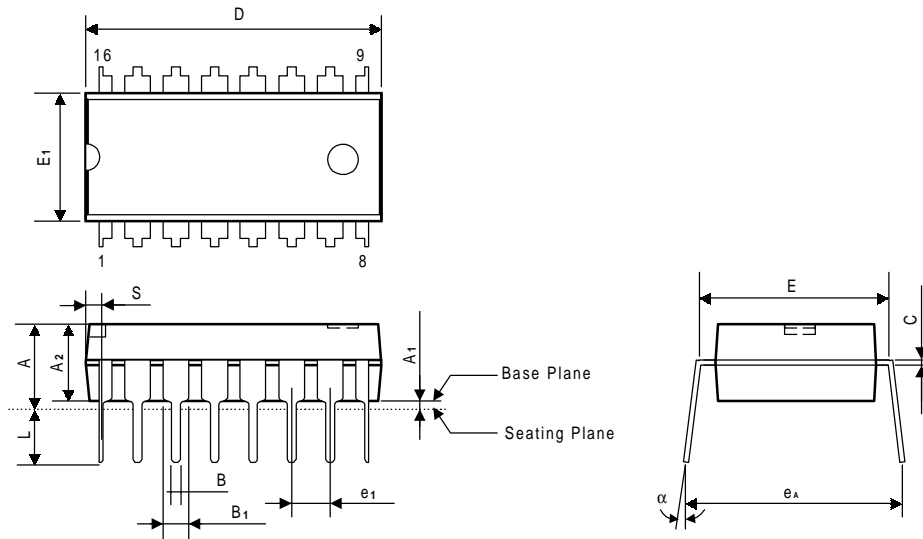

Symbol	Dimensions in inches	Dimensions in mm
A	0.175 Max.	4.45 Max.
A ₁	0.010 Min.	0.25 Min.
A ₂	0.130±0.010	3.30±0.25
B	0.018 +0.004 -0.002	0.46 +0.10 -0.05
B ₁	0.060 +0.004 -0.002	1.52 +0.10 -0.05
C	0.010 +0.004 -0.002	0.25 +0.10 -0.05
D	0.750 Typ. (0.770 Max.)	19.05 Typ. (19.56 Max.)
E	0.300±0.010	7.62±0.25
E ₁	0.250 Typ. (0.262 Max.)	6.35 Typ. (6.65 Max.)
e ₁	0.100±0.010	2.54±0.25
L	0.130±0.010	3.30±0.25
α	0° ~ 15°	0° ~ 15°
e _A	0.345±0.035	8.76±0.89
S	0.040 Max.	1.02 Max.

Notes:

1. The maximum value of dimension D includes end flash.
2. Dimension E₁ does not include resin fins.
3. Dimension S includes end flash.

Package Information
DIP 18L Outline Dimensions

unit: inches/mm

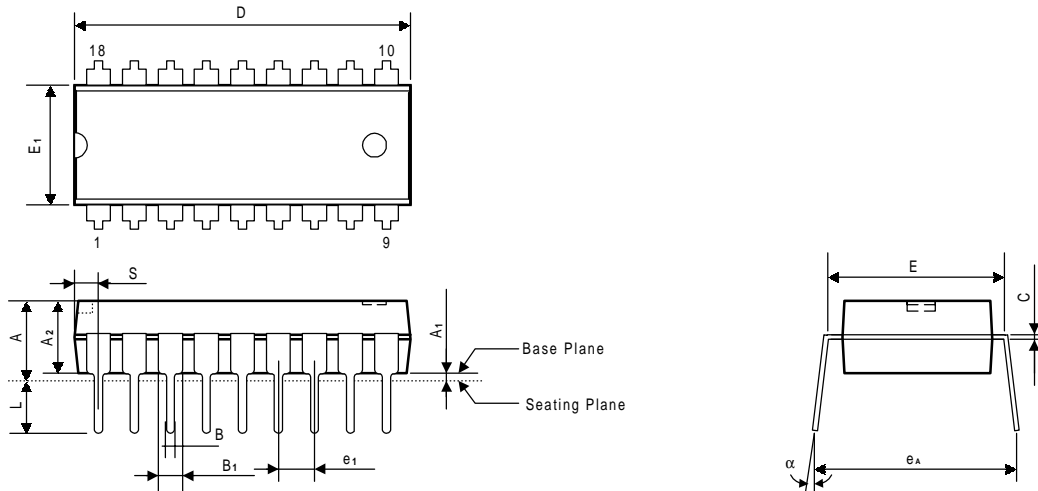

Symbol	Dimensions in inches	Dimension in mm
A	0.175 Max.	4.45 Max.
A1	0.010 Min.	0.25 Min.
A2	0.130±0.010	3.30±0.25
B	0.018 +0.004 -0.002	0.46 +0.10 -0.05
B1	0.060 +0.004 -0.002	1.52 +0.10 -0.05
C	0.010 +0.004 -0.002	0.25 +0.10 -0.05
D	0.900 Typ. (0.920 Max.)	22.86 Typ. (23.37 Max.)
E	0.300±0.010	7.62±0.25
E1	0.250 Typ. (0.262 Max.)	6.35 Typ. (6.65 Max.)
e1	0.100±0.010	2.54±0.25
L	0.130±0.010	3.30±0.25
α	0° ~ 15°	0° ~ 15°
eA	0.345±0.035	8.76±0.89
S	0.055 Max.	1.40 Max.

Notes:

1. The maximum value of dimension D includes end flash.
2. Dimension E1 does not include resin fins.
3. Dimension S includes end flash.

Package Information
DIP 20L Outline Dimensions

unit: inches/mm

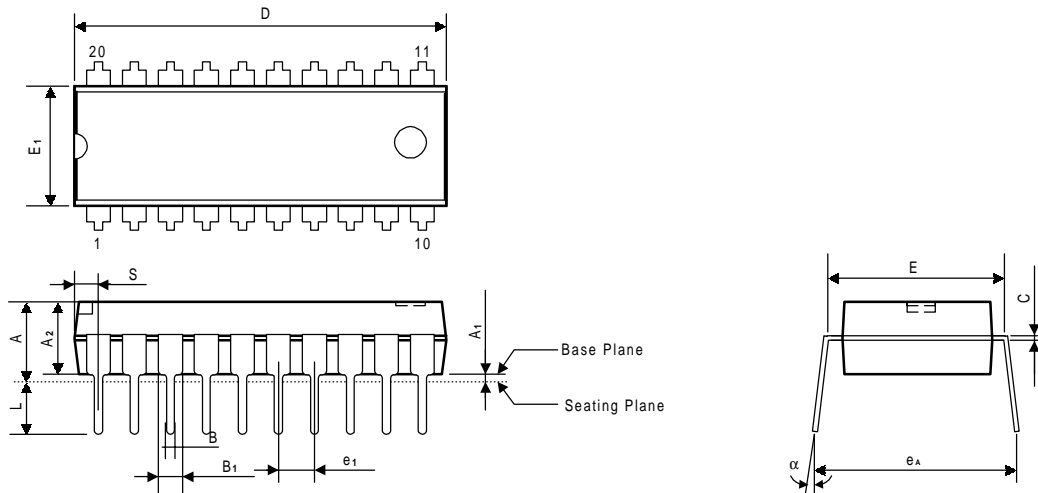

Symbol	Dimensions in inches	Dimensions in mm
A	0.175 Max.	4.45 Max.
A1	0.010 Min.	0.25 Min.
A2	0.130±0.010	3.30±0.25
B	0.018 +0.004 -0.002	0.46 +0.10 -0.05
B1	0.060 +0.004 -0.002	1.52 +0.10 -0.05
C	0.010 +0.004 -0.002	0.25 +0.10 -0.05
D	1.026 Typ. (1.046 Max.)	26.06 Typ. (26.57 Max.)
E	0.300±0.010	7.62±0.25
E1	0.250 Typ. (0.262 Max.)	6.35 Typ. (6.65 Max.)
e1	0.100±0.010	2.54±0.25
L	0.130±0.010	3.30±0.25
α	0° ~ 15°	0° ~ 15°
eA	0.345±0.035	8.76±0.89
S	0.078 Max.	1.98 Max.

Notes:

1. The maximum value of dimension D includes end flash.
2. Dimension E1 does not include resin fins.
3. Dimension S includes end flash.